

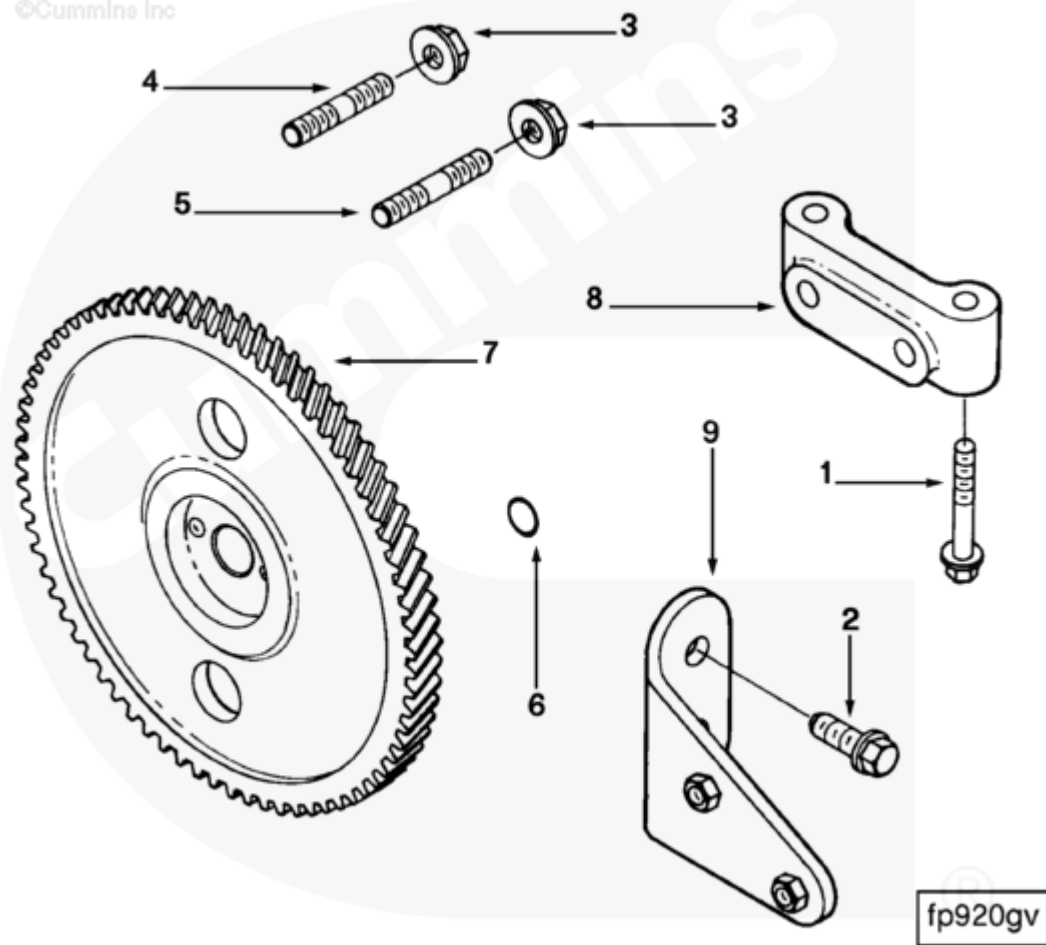

Parts Catalog - Option Detail

Electronic Parts Catalog - Option Detail				
Option	Group	Graphic	Film Card	Date
FP97272-01	09.01	fp920gv	Z	15-MAY-95
Engines	6C8.3, C GAS PLUS CM556, G8.3, G8.3 CM558, GTA8.3 CM558, ISC CM2150, ISC CM554, ISC CM850, ISC8.3 CM2250, ISC8.3 G CM2180 C101, ISL CM2150, ISL CM554, ISL CM850, ISL G CM2180, ISL8.9 CM2150 L110, ISL8.9 CM2880 L112, ISL9 CM2150 SN, ISL9 CM2250, ISL9 CM2350 L101, ISL9 CM2350 L111, ISLE4 CM850, L GAS PLUS CM556, L8.9, L8.9 L121, L8.9G CMOH2.0 L125B, L9 CM2350 L116B, L9 CM2350 L119B, L9 CM2350 L120C, L9 CM2350 L123B, L9.3 L105, L9.5 L117, L9N CM2380 L124B, QSC8.3 CM2250, QSC8.3 CM2880 C102, QSC8.3 CM554, QSC8.3 CM850(CM2850), QSL9 CM2250, QSL9 CM2250 L115, QSL9 CM2350 L102, QSL9 CM2350 L107, QSL9 CM2350 L118, QSL9 CM2350 L122, QSL9 CM554, QSL9 CM850(CM2850), QSL9 G CM558, QSL9 M CM2250 L106, QSL9.3 CM2880 L113			



[SMALL](#) | [MEDIUM](#) | [LARGE](#)

Cart	Ref No	Part Number	Part Description	Required	Remarks
View My Cart					
		FP97272-01	Fuel Pump Coupling		FUEL PUMP COUPLING...(More)

					Engine Family: C Series
					Fuel Pump Mfg/Model:
					Nippondenso EP-9
					Aspiration:
					Jacket Water Aftercooled
					Fuel pump gear less keyway.
					For engines with locktime
					pumps. The (2) 3907978 studs
					(short) are to be used in the
					in-board mounting holes.
					DEP May Substitute 3282372 in
					Place of 3915036.
<input type="checkbox"/>	1	3900633	Hexagon Flange Head Cap Screw	4	M8 X 1.25 X 50
<input type="checkbox"/>	2	3902460	Hexagon Flange Head Cap Screw	2	M10 X 1.50 X 25.
<input type="checkbox"/>	3	3902662	Hexagon Flange Nut	4	M10 x 1.50
<input type="checkbox"/>	4	3907978	Stud	2	M10 x 1.50(Both Ends) x 50
<input type="checkbox"/>	5	3915036	Stud	2	
<input type="checkbox"/>	6	3916284	O-Ring Seal	1	
<input type="checkbox"/>	7	3920553	Fuel Pump Gear	1	
<input type="checkbox"/>	8	3920638	Fuel Pump Support	1	
<input type="checkbox"/>	9	3920639	Fuel Pump Brace	1	